

APS Arosio si riserva a termine di legge la proprietà del presente disegno con divieto di riproduzione o comunicazione a terzi senza sua autorizzazione. This drawing is a proprietary document and shall not be reproduced or released to other except as otherwise authorized by APS Arosio

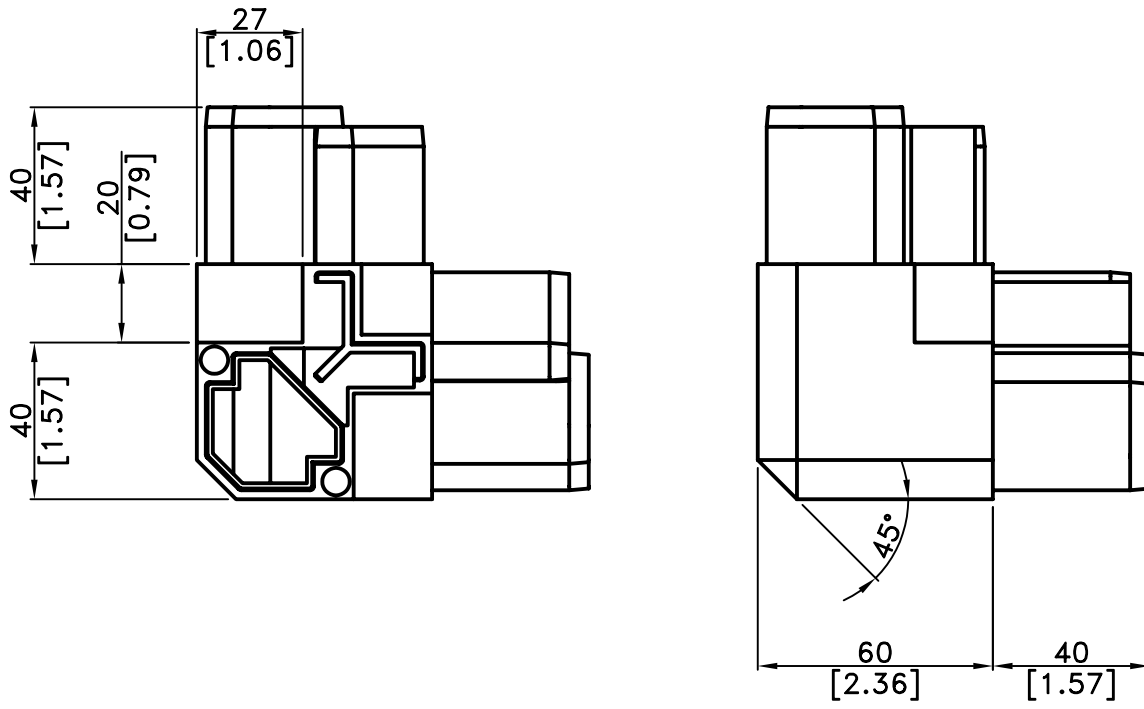

MATERIALE MATERIAL	NYLON+FV / NYLON+FG	TRATTAMENTO TREATMENT	-
TIPO TYPE	PA6 FV20% / PA6 FG20%	PESO WEIGHT	155 gr - 0.341 Lb
DENOMINAZIONE ANGOLO IN NYLON PER PROFILO TAGLIO TERMICO DA 40mm PER PANNELLO 25mm			
DENOMINATION NYLON CORNER FOR THERMAL BREAK PROFILE FOR 40mm / 1.77inc FOR PANEL 25mm / 0.98in			



SCALA SCALE	1:2	
DISEGNO N. DRAWING N.	A1510021	
CODICE / CODE		FORMATO SIZE
AFGTT40-25		A4